



 H.H. SCOTT

stereomaster high fidelity components for 1960

What is High Fidelity Sound?

It is the creation in your own living room of the true beauty and depth of the original performance as played in the concert hall. Actually it is a combination of silence and truth because high fidelity sound reproduction means the absence of extraneous noise and hum, and faithful, distortionless, delivery of the sound you want to hear.

What is Component High Fidelity?

With component high fidelity all the essential parts of the music system are purchased as separate units. These separate units include: The record changer, amplifier, loudspeaker, and radio tuner. In conventional radio-phonographs all these parts are manufactured together and installed in one cabinet.

Why is Component High Fidelity Better?

With components the value is concentrated in the electronic equipment, rather than in

the furniture. When you buy components you pick the particular parts you want to fill your needs and plug them together to form a complete system. With components you can separate the loudspeaker from the record playing equipment so that speaker sound vibration will not interfere with the perfect reproduction of the recording. The smaller companies who manufacture fine components can maintain higher standards of quality and performance than is possible in the mass-produced console.

What Are the Different Components?

The Radio Tuner captures the radio waves from the air. There are two kinds of radio waves: AM and FM. AM is the kind you find in most ordinary table radios. FM is a newer form of static-free radio being used to transmit a great deal of good music.

The Record Player is usually in the form of a turntable or a record changer in the high fidelity system. It is a precision piece of equipment, made like a fine watch. Mounted on the turntable or changer is the arm and cartridge. The cartridge holds the phono-

graph needle and transforms the movement of the needle in the record groove to electrical signals.

The Amplifier is the link between the tuner or turntable and the speakers. The amplifier strengthens the minute signals fed into it by the tuner or record player . . . turns these signals into electrical impulses strong enough to drive the speakers. It is in the amplifier that you control the sound . . . make it louder or softer . . . or change the tonal balance to suit your ears.

The Speaker. It is here that the carefully controlled electrical signal is changed into sound waves you can hear.

Why Should I Buy Components?

Components give you the ultimate in performance. When you buy components you don't spend a lot of money on expensive cabinetry. All of your purchase price goes for the "guts" or insides of the set. Therefore you get *more* for your money. You also get extra versatility with components. They take little space, and can be installed almost anywhere.

... both stereophonic and monophonic

How Much Does High Fidelity Cost?

A component system can be purchased for as little as \$200 or you can spend over \$1000. The *only* reason, however, for purchasing high fidelity is quality. Therefore you are defeating your purpose if you buy inexpensive components. You should purchase the very best components you can afford. It is better to wait, rather than to compromise.

What Shall I Buy and Where Shall I Buy It?

There are a few basic facts to remember when you purchase high fidelity components. First: Go to a reliable dealer . . . one who will stand behind the equipment he sells . . . one who is experienced enough to aid you in choosing fine equipment. A good guide is to see whether the dealer carries H. H. Scott equipment. H. H. Scott gives their franchise *only* to qualified dealers.

When you walk into your dealer's shop, start by telling him how much you can afford to spend. Be frank about this figure, then he won't show you a \$500 speaker, when all you can spend is \$200. Remember,

buy the best you can afford.

You must consider this as a long-range investment rather than something you will buy again next year. If your budget is limited we suggest a step by step method of acquiring a system:

1 Buy *either* a tuner *or* a turntable. You must have at least one signal source for your system. Many people start with a tuner, then add a phonograph at a later date. This is logical because once you buy a tuner you have no further expenses. You don't have to go right out and buy records. Note: Even if you buy a monophonic phono system, we recommend you purchase a stereo cartridge as a guard against obsolescence. You can play monophonic recordings with a stereo cartridge but you *can't* play stereo records with a monophonic cartridge.

2 You must have an amplifier in your system. There are two ways to buy:

A Buy a stereo amplifier. Even if you don't purchase two speaker systems now, you will be all set for stereo whenever you want.

B Buy a monophonic amplifier now, and a single speaker system. Then when you are ready for stereo you can purchase a

matching amplifier and speaker and a Scott Stereo-Daptor.

What is Stereo?

There are now two systems of high fidelity, monophonic (monaural) and stereophonic. Monophonic is a system that starts from one microphone and is fed through a single high fidelity set. Stereophonic is a double system. Two microphones are placed at different sides of the orchestra and two different systems are used to keep the two signals or channels separated. Two separate speakers are used, placed on different sides of your room. Stereo is much like 3-D photography. Two slightly different sounds reach your ears giving you a new dimension in sound. (See next page.) H. H. Scott has designed many special components for stereo. First is a stereo arm and cartridge to give true high fidelity performance from the new stereo records. Next is a stereophonic AM-FM tuner with two completely separate sections to pick up stereo broadcasts transmitted by many AM and FM stations. H. H. Scott has also designed several stereo amplifiers, that are essentially two amplifiers in one, giving you completely separate control over both stereo channels.

how **STEREO** works

1 Two separate microphones are placed at opposite sides of the orchestra. 2 The separate signals from the microphones are recorded on two separate sides of a record groove. 3 The stereo cartridge senses the two signals, separates them and feeds them into a dual stereo amplifier. 4 The amplifier strengthens the weak signal from the cartridge and provides you with controls to tailor the sound to your room and your ears. 5 The two separate signals are fed into two speakers placed at opposite sides of your room. This gives you 3-D sound . . . two slightly different sound pictures, one for each ear, that create a dimensional effect. 6 As an alternate system the sound can be fed from the two microphones to separate AM and FM stations. 7 These separate signals are then picked up by a dual stereo AM-FM tuner and fed to the stereo amplifier.

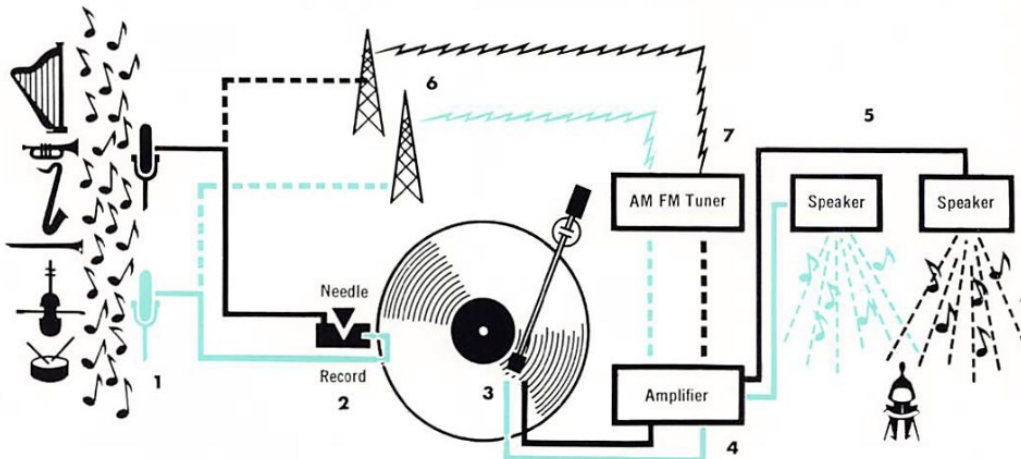

There are two principal ways to purchase H. H. Scott stereo. If you already have a monophonic system, or prefer to start with monophonic and expand to stereo later, you can add the H. H. Scott Stereo-Dapter. If you want to go into stereo from the start you can purchase H. H. Scott components designed specifically for stereo.

**Exclusive H. H. Scott
Laboratory
Standard Guarantee
Assures
Excellence**



Every H. H. Scott component is furnished with a bonded guarantee to assure you that it meets or exceeds the technical specifications claimed for it. This guarantee is made possible by the stringent quality control tests given each H. H. Scott component before it leaves the factory.

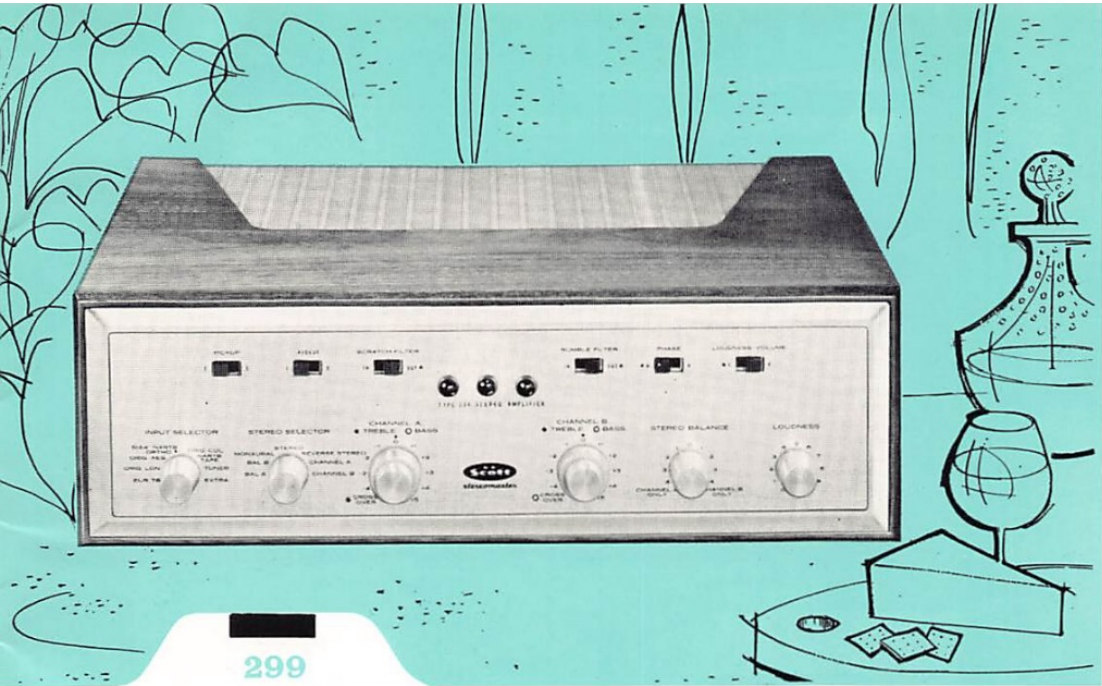

299

**40 Watt
Stereo
Amplifier**

The H. H. Scott 299 is the ultimate in complete stereo amplifiers. Introduced just a year ago, it is now in use in more fine music systems than any other stereo amplifier in the world. It has won praise from many leading high fidelity experts. It was "check-rated" and recommended by both leading consumer testing organizations. The 299 was selected for display at world expositions like the Moscow Fair.

This proven 40 watt stereo amplifier will drive even the most inefficient speaker systems because its special sub-sonic filter directs all power into the audible music range and its output stage is of extremely conservative design. This fine amplifier gives you a unique combination of exclusive H. H. Scott features, advanced engineering, and handsome appearance. If you are planning a truly fine music system the H. H. Scott 299 complete amplifier is the ideal choice.

299

important features

- 1 Provision for connecting a stereo phono cartridge and stereo tape heads or two phono cartridges.
- 2 D.C. Filament supply for pre-amp to virtually eliminate hum (80 db below full power output).
- 3 Separate record scratch and rumble filters.
- 4 40-watt power stage consisting of dual 20 watt power amplifiers, to meet the requirements of today's speaker systems.
- 5 Unique visual signal light panel to indicate mode of operation.
- 6 Stereo tape recorder output.
- 7 Phase reverse switch to compensate for improperly phased tape recordings or loudspeakers.
- 8 Third channel output.
- 9 Special compensation for direct connection of tape playback heads without external pre-amp.
- 10 Special switching lets you use your stereo pickup on monophonic records.
- 11 You can play a monophonic source such as an FM tuner through both channels simultaneously, effectively doubling power.
- 12 Can be used as an electronic crossover (bi-amplifier).
- 13 Completely separate Bass and Treble controls on each channel so that different speakers may be matched.
- 14 Special balancing circuit for quick and accurate volume balancing of both channels.
- 15 Loudness compensation. For complete specifications see page 18.

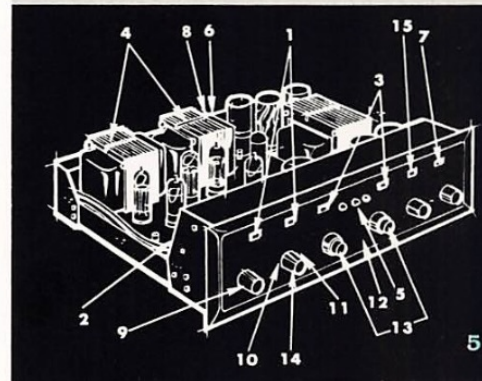

**All H. H. Scott
Stereo Amplifiers
Feature
Unique Third Channel**

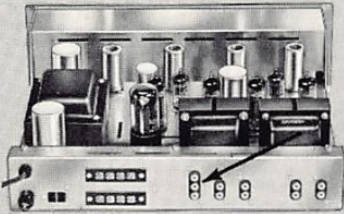

One of the many exclusive stereo features pioneered by H. H. Scott is the third (or middle) channel. This extra output is used in conjunction with an auxiliary amplifier to fulfill several important needs: **1** It gives fuller sound, particularly in large rooms where it is desired to separate speakers by more than eight feet. **2** It allows ideal seating for full stereo in a much greater portion of your listening room giving you greater freedom in placement of speakers and furniture. **3** It lets you feed a full signal to extension speaker systems in other rooms like kitchen, den, porch, bedroom or bath. With an ordinary two channel system you feed just half the signal to an extension speaker. This new H. H. Scott center channel feeds a mixture of *both* signals into a single extension speaker when desired.

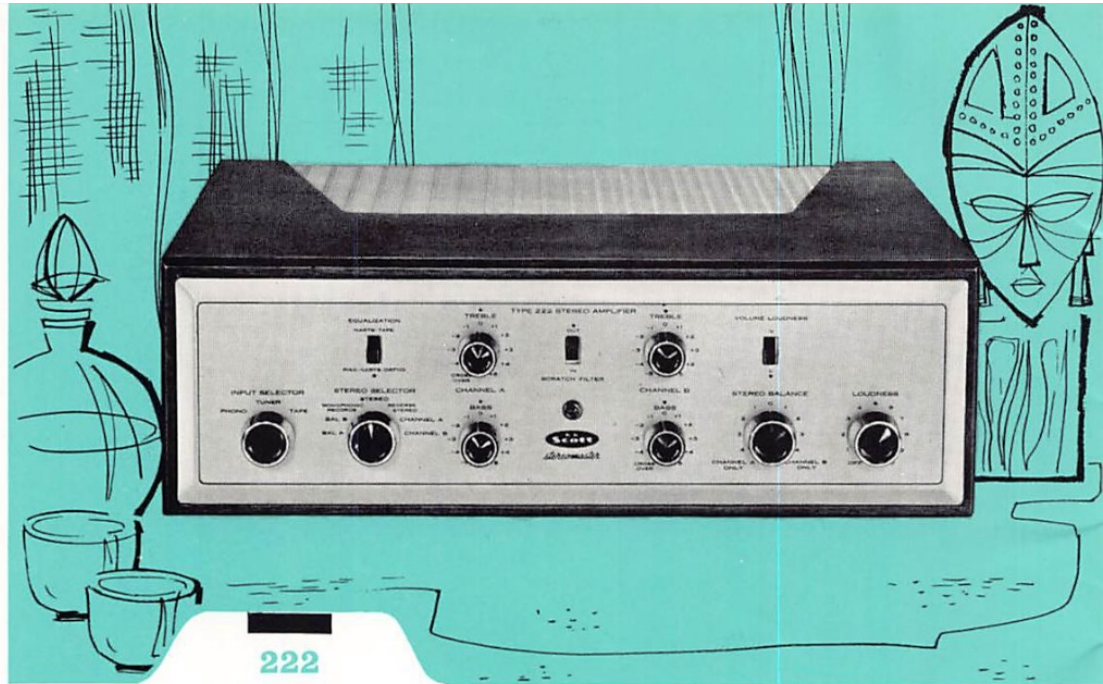

222

**24 Watt
Stereo
Amplifier**

Here at last is a budget priced stereo amplifier with many features usually found only in more expensive equipment. These features include third channel, separate tone controls, special balancing provisions, DC preamp heaters, sub-sonic filter and many others. It is backed by H. H. Scott's reputation for quality and engineering leadership. Its dual conservatively rated 12 watt output stages are sufficient for the most popular inefficient speaker systems. If you are planning a medium-priced system you will find the new H. H. Scott 222 your best buy. For complete specifications see page 18.

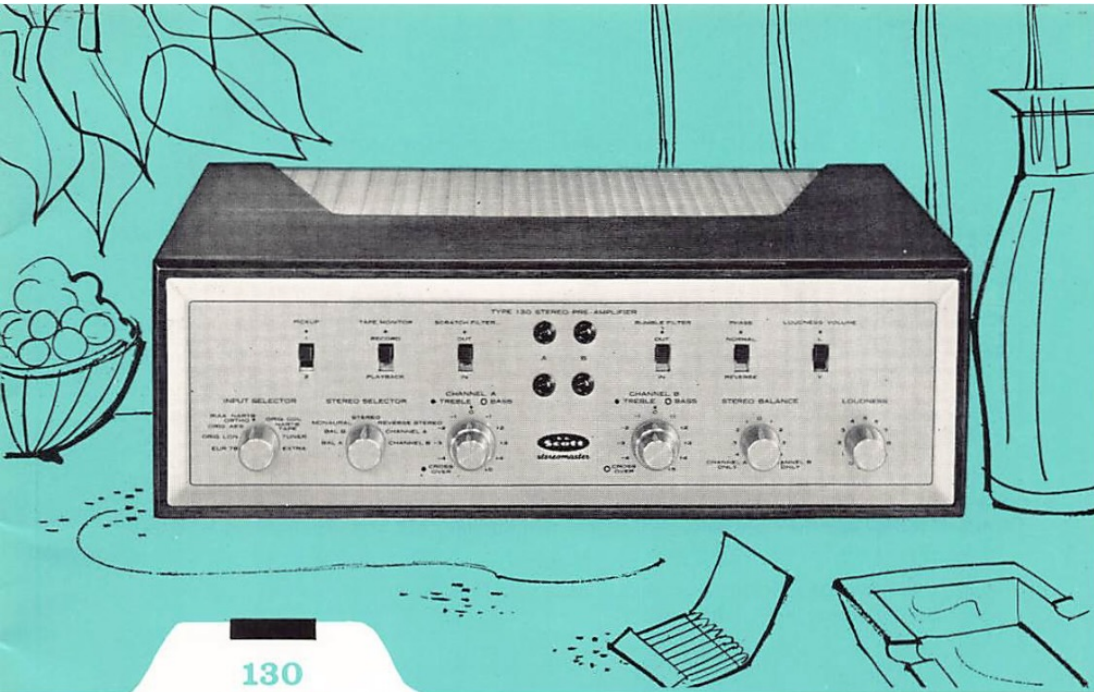

130

**Stereo
Preamplifier**

This stereo control center has all the operating features of the model 299 plus tape monitoring facilities, special high gain channel for tape heads, and separate stereo input level controls. It is used where the very optimum in stereophonic reproduction is required; where it is desired to separate the heat-producing power amplifier from the control location; or where higher power is desired than is available in integrated amplifiers. HI FI REVIEW magazine reports that the 130 "... has so much flexibility that it defies adequate editorial treatment."

**130
important features**

1 Visual signal light display panel shows mode of operation at a glance. 2 Completely separate bass and treble controls on each channel so that different speakers may be matched. 3 Play stereo from any source—Records, FM-AM Tuner, Tape. 4 Reverse channels instantly, or play monophonic from any source through both channels doubling your power. 5 Special switching lets you use your stereo pickup on monophonic records. 6 Special circuitry lets you balance channels quickly and accurately. 7 Play stereo—center channel output lets you use your present speaker as a middle channel. 8 Reverse the phase of one of your channels 180 degrees instantly. Lets you correct for improperly recorded tapes. 9 Separate 12 db/octave rumble and scratch filters. 10 Complete record equalizer facilities. 11 Use as an electronic crossover at any time. 12 Two stereo low-level inputs. You can connect both a stereo phono pickup and stereo tape head. 13 Stereo tape recorder inputs and outputs. 14 Provisions for operating stereo tape heads without external preamps. 15 Quick-set dot controls allow any member of your family to use equipment. 16 Loudness-volume switch. 17 Stereo tape monitor switch. For complete specifications see page 18.

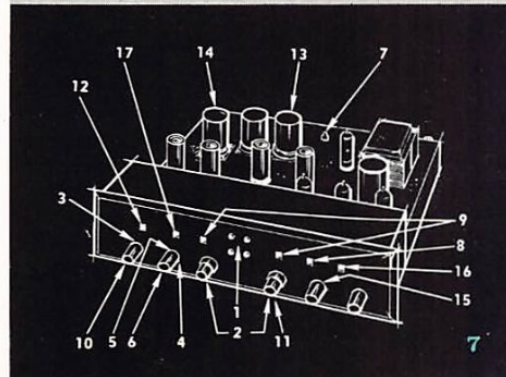

**Hermon
Scott...
Audio
Pioneer**



Hermon H. Scott received B.S. and M.S. degrees from M.I.T. Inventor of the RC Oscillator, RC tuned circuits and filters, the Dynamic Noise Suppressor and other devices; he has many U. S. and foreign patents. His technical leadership was recognized by election as Fellow in the Institute of Radio Engineers, Acoustical Society of America, and Audio Engineering Society, and by numerous awards, including the Potts Medal. He is the author of many technical papers and articles.

H. H. Scott . . . a history of leadership in the Acoustic field

To insure that every H. H. Scott component meets the highest standards of quality, H. H. Scott maintains this ultra modern plant for the design and manufacture of all its components.

This new plant, located in Maynard, Massachusetts, includes a machine shop, sheet metal facilities, coil and transformer department, electrical assembly department and fully equipped laboratories for design and research.

The engineering department is staffed by 12 graduate engineers who are primarily concerned with developing new and better components for high fidelity sound.

Every high fidelity component receives over 50 electrical and mechanical tests before it leaves the factory. Special electrically shielded "screen rooms" are used for aligning FM tuners. There are life test facilities where components are run for thousands of hours under strict controls to test their durability.

These extensive investments in facilities back up H. H. Scott's philosophy that there will never be any compromise with quality.

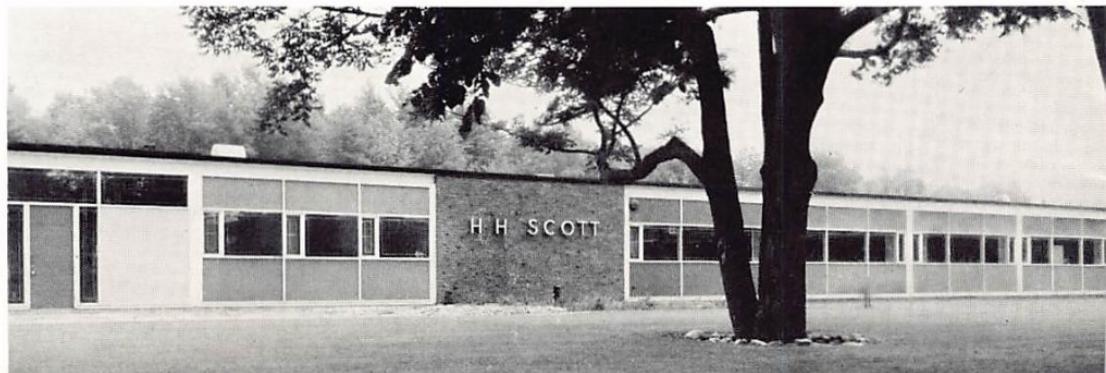



250

**40 Watt
Power
Amplifier**

The unique "Power-Balance" output circuitry of this amplifier results in performance equal to amplifiers of much higher power rating. Output transformer is of exclusive H. H. Scott design. Rugged 6CA7 output tubes are used, operating far below maximum ratings. Two 250's are ideal for use with the 130 Stereo preamp, combining to give stereo playback systems of unexcelled quality.

250

technical specifications

Power Ratings: 40 watts on music waveforms; 80 watts peak; 36 watts for laboratory applications.

Frequency Response: 12 cps to 60,000 cps.

Noise and Hum: 85 db below full output.

Harmonic Distortion: less than 0.5%.

IM Distortion: 0.1% first order difference tone IM (CCIF method).

Inputs: 0.5 volt and 1.5 volt inputs for full output; input level control.

Outputs: 4, 8 and 16 ohm output taps.

Circuitry: 6CA7 output tubes; separate bias supply; adjustments for DC and AC bias and balance; fused; H. H. Scott-designed output transformers.

Dimensions in Accessory Cage: 13" w x 9½" d x 7" h.



399

important features

1 Separate Silver-Sensitive FM Front End, heavily silver plated for maximum sensitivity and reliability. Meets all FCC radiation specifications. 2 Highly sensitive, separate AM front-end. 3 Separate AM and FM professional tuning controls for precise station selection. 4 Wide-Band FM detector for distortion-free reception on all signals. 5 Separate tuning eyes for FM and AM. 6 New wide-range AM detector for high fidelity performance on AM stations. 7 Switching provisions for FM multiplex stereo or FM-FM stereo. 8 Provision for connecting a stereo phono cartridge and stereo tape heads or two phono cartridges. 9 D.C. Filament supply for preamp to virtually eliminate hum (80 db below full power output). 10 Separate record scratch and rumble filters. 11 40 watt power stage consisting of dual 20 watt power amplifiers, to meet the requirements of today's speaker systems. 12 Phase reverse switch to compensate for improperly phased tape recordings or loudspeakers. 13 Third channel output. 14 Special switching lets you use your stereo pickup on monophonic records. 15 Completely separate Bass and Treble controls on each channel so that different speakers may be matched. 16 Special balancing circuit for quick and accurate volume balancing of both channels. 17 Tape monitor switch. For complete specifications see pages 18 and 19.

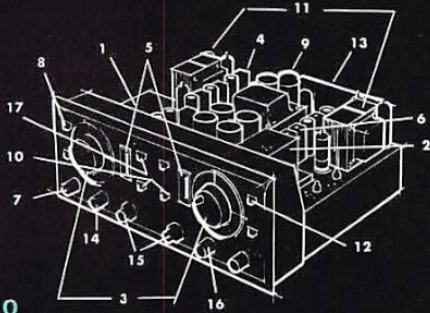

NOW... From the world-famous
Engineering Laboratories of H. H. SCOTT

THE 399... A NEW STEREO TUNER/AMPLIFIER COMBINATION WITH NO COMPROMISE IN QUALITY

399

Stereo Tuner Amplifier Combination

Until now the high fidelity enthusiast had to compromise if he wanted a *combined* stereo tuner/amplifier. There were none on the market that performed as well as fine separate components. Now, after two years of intensive research and development, H. H. Scott introduces the 399 . . . consisting of the famous 299 40 watt stereo amplifier *and* the time-tested 330D AM-FM stereo tuner wedded together on one compact chassis . . . a masterpiece of engineering design.

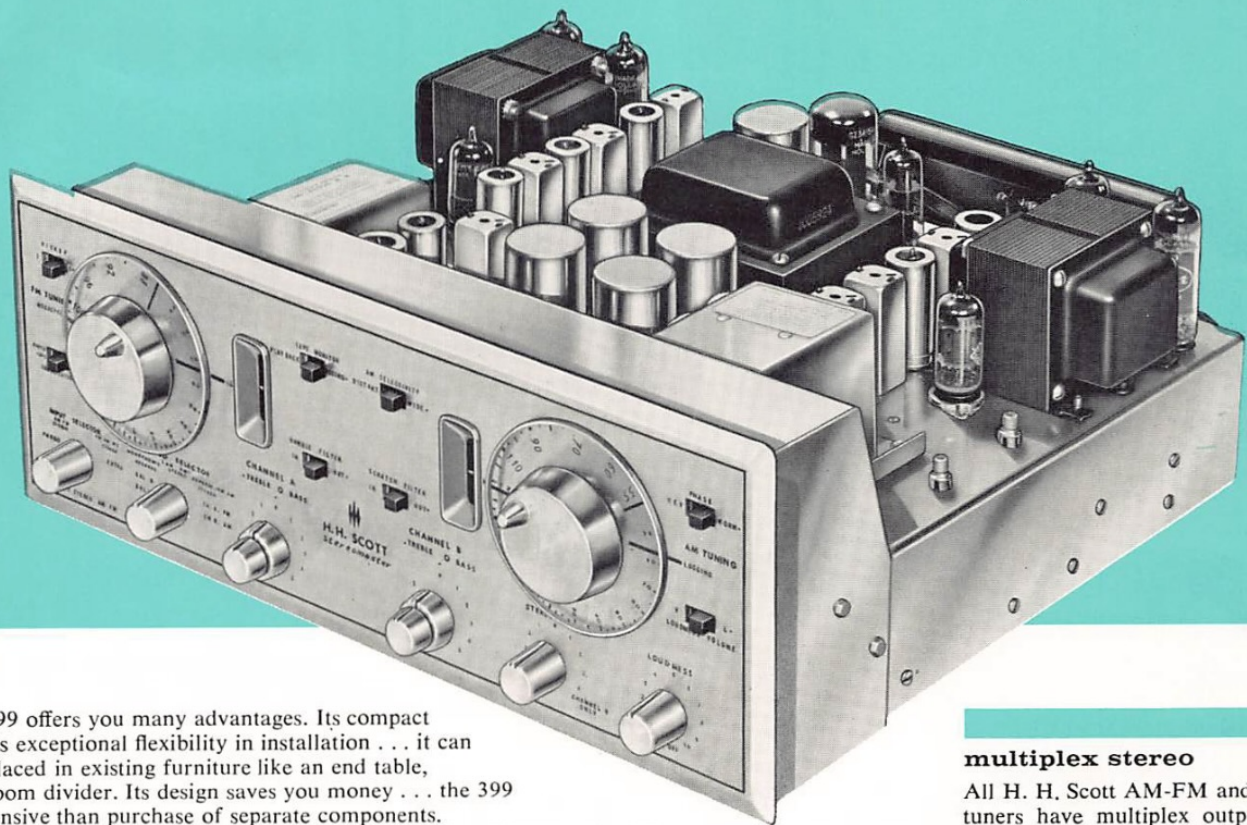

The new 399 offers you many advantages. Its compact design gives exceptional flexibility in installation . . . it can be easily placed in existing furniture like an end table, buffet or room divider. Its design saves you money . . . the 399 is less expensive than purchase of separate components. Its design centralizes all controls on one panel to simplify system operation. See pages 18 and 19 for complete technical specifications.

multiplex stereo

All H. H. Scott AM-FM and FM only tuners have multiplex output for instant conversion to multiplex stereo.

330D

important features

1 Separate Silver-Sensitive FM Front End, heavily silver plated for maximum sensitivity and reliability. Meets all FCC radiation specifications. 2 Highly sensitive, separate AM front-end. 3 Separate AM and FM professional tuning controls for precise station selection. 4 Wide-Band FM detector for distortion-free reception on all signals. 5 Highly selective FM IF stages permit separation of stations close together on dial. 6 New wide-range AM detector for high fidelity performance on AM stations. 7 Selector switch with these positions: Off, Mono, Stereo, Stereo Phase Reverse. 8 Band switch with these positions: FM, AM Wide, AM Normal, AM Distant. 9 Illuminated professional signal strength and tuning meter. 10 Stereo output jacks. 11 Special jack for instant connection of accessory multiplex adaptor. 12 Separate stereo tape recorder output jacks. 13 Highly sensitive AM Ferrite Loop Antenna. 14 Chassis specially constructed of heavy copper bonded to aluminum to insure reliability and high sensitivity over many years of use. 15 Separate level controls on AM and FM output channels. 16 10 KC whistle filter eliminates heterodyne whistle on wide range AM reception. For complete specifications see page 19.

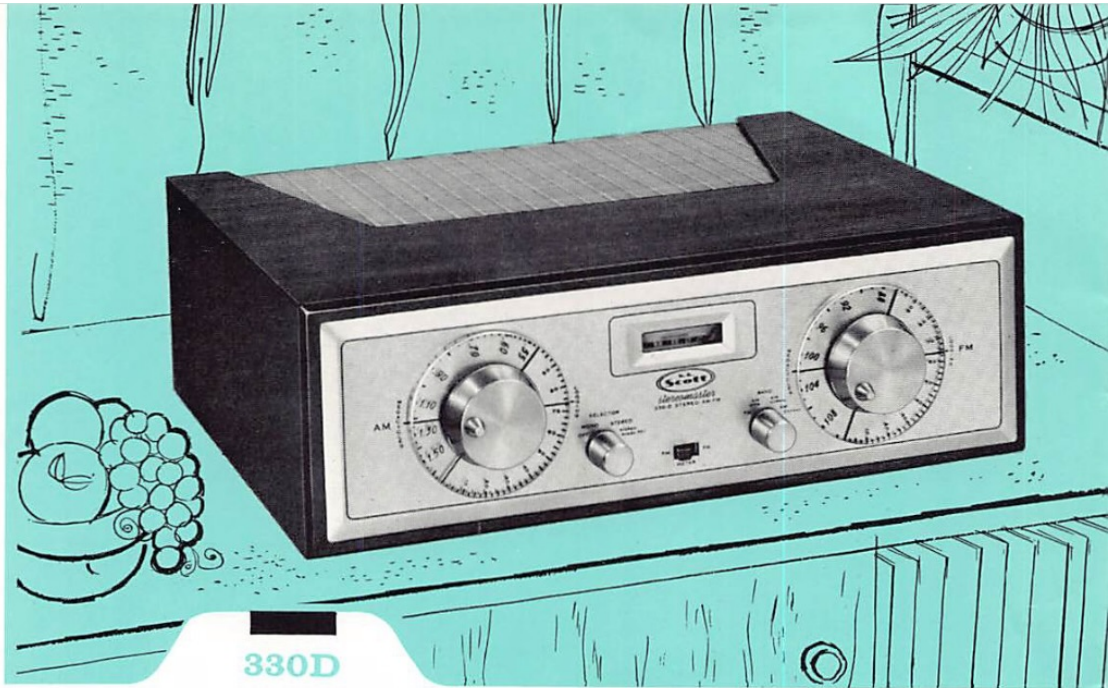

330D

AM-FM Stereo Tuner

The AM and FM sections of this fine tuner are completely separated and function independently for receiving AM-FM stereo broadcasts. The FM section uses H. H. Scott's exclusive Wide-Band Design. The AM section utilizes another H. H. Scott exclusive, Wide-Range circuitry, to give you AM reception comparable with fine FM. More 330 tuners have been sold than any other stereo tuner and there's a reason . . . As *Audiocraft* reported: ". . . a very high quality FM tuner combined with an AM tuner which is easily the best we have heard." *High Fidelity Magazine* stated: "The cleanest and most transparent FM signals I have heard in a long time."

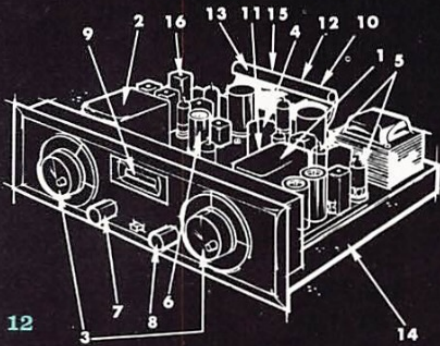



320

AM-FM Tuner

The many fine features built into this superb AM-FM tuner have never before been available for under \$200. Combined on one compact chassis are such famous H. H. Scott engineering features as Wide-Band FM circuitry to give you high selectivity with complete freedom from drift; Wide-Range AM circuitry for perfect reception of high fidelity AM broadcasts; and H. H. Scott's specially designed "front end" for maximum sensitivity and reliability. Special switch permits control of multiplex adaptor from front panel. The 320 tuner is ideal for medium priced high fidelity systems where stereo AM-FM reception is not desired. See page 19 for complete specifications.

Famous H. H. Scott Wide-Band Design Means Better FM Reception

Wide-Band FM tuner design is recognized as one of the most significant of H. H. Scott's many contributions to audio science. It assures you of absolutely drift-free and interference-free reception in even the weakest signal areas. It also results in ability to separate stations so close together on the dial that ordinary tuners would pass them by.

Exclusive H. H. Scott Wide-Band design is the only way you can get high sensitivity without sacrificing distortion-free response over the entire audio spectrum. It also assures perfect multiplex reception.

In AM circuitry the unique H. H. Scott Wide Range detector is equally important. For the first time you can receive full frequency AM broadcasts with fidelity and frequency response comparable to FM.

Custom Installation

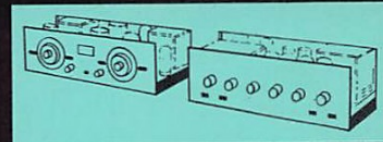

The beautiful styling and unique construction of H.H.Scott components make them easily adaptable to custom installations. Only one simple cutout is required for panel mounting, and units do not have to be taken apart, nor are escutcheons required. Units slide into place easily like drawers.

H. H. Scott's Engineering Leadership Recognized With These Important Awards

Selected for display at the Moscow Fair, the Brussels World Fair and the Milan Triennale; Electrical Manufacturing Award for outstanding instrument design; Two A.I.M. Merit Awards; Audio Engineering Society's Potts Memorial Medal to Hermon Scott for outstanding contributions to audio science; Medal of Merit at the International Sight and Sound Exposition.

Silver Sensitive Front End

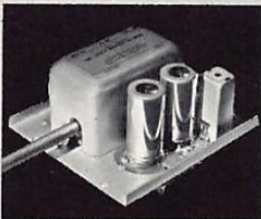

H. H. Scott never compromises on design. The "front end" pictured above is a good example. Only H. H. Scott, of all manufacturers, heavily silver-plates their cascade RF "front ends" to attain both maximum sensitivity and most reliable performance. Because of this care in design you will get perfect reception of stations whose signals are too weak for tuners with conventional circuitry.

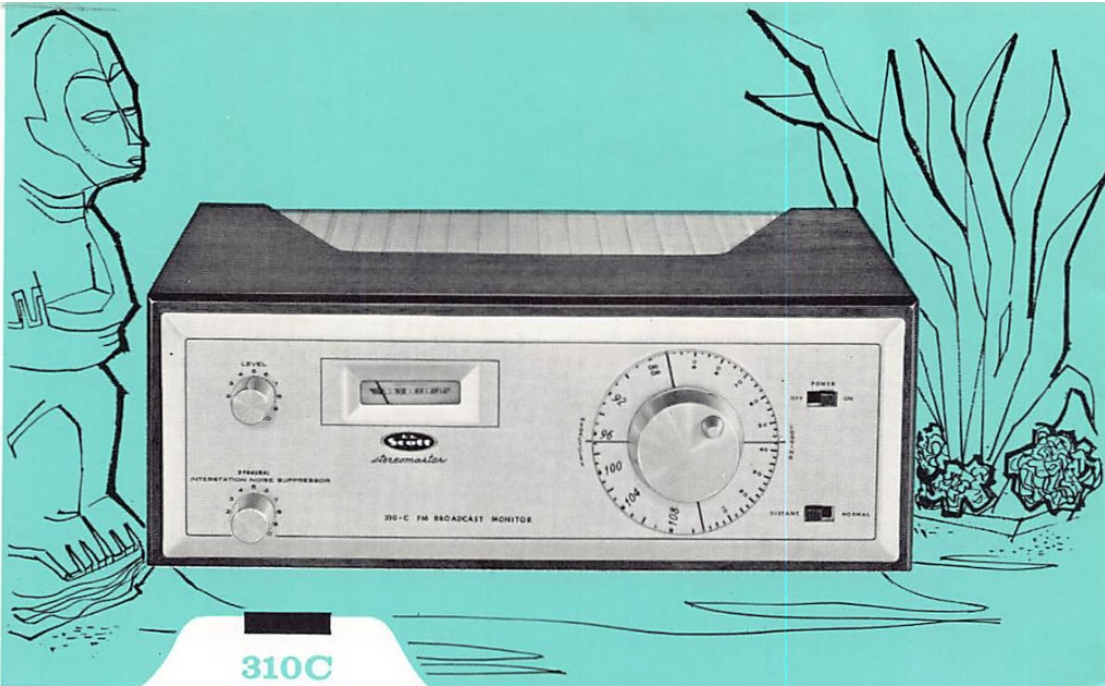

310C

Broadcast Monitor FM Tuner

Designed for the perfectionist and connoisseur, the 310C is the most sensitive tuner it is possible to make at this stage of the art. It finds application in professional broadcast relay work, and in home listening where the absolute optimum in performance is required. Outstanding features include heavily silver-plated RF circuitry, professional illuminated signal strength meter and interstation noise suppressor. HIGH FIDELITY Magazine says of this fine instrument: The 310 "... is a tuner that seems as close to perfection as is practical at this time." See page 19 for complete specifications.

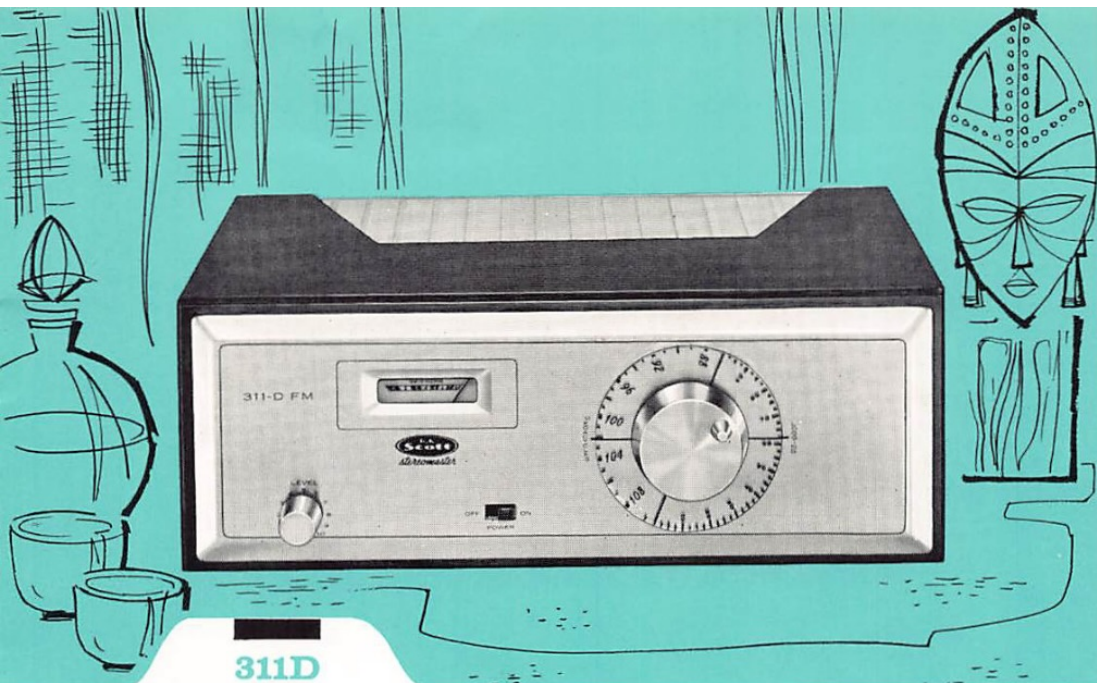

311D

FM Tuner

Here is an outstanding FM tuner, incorporating all the benefits of H. H. Scott engineering leadership at a moderate price. The 311D features wide-band design, unique silver-plated RF section, and professional illuminated signal strength meter. *AUDIO* magazine said of the 311 "Hermon Hosmer Scott has always had a reputation for making fine products, and even though the 311 FM tuner is low priced . . . it turns in a performance and quality report that is enviable." This fine tuner is ideal for moderately priced systems where AM reception is not desired. See page 19 for complete specifications.

**Here is what
the experts say about
H. H. Scott Products**

London-Scott Arm & Cartridge: "Best pickup, barring none, regardless of price." — *Hi Fi Systems*. "The ne plus ultra of stereo cartridges." — *The Gramophone*. "The London-Scott is still without a serious rival" — *Saturday Review*. **The 299 Stereo Complete Amplifier** is the only stereo amplifier to receive top ratings from both of America's best known consumer testing organizations. Both also suggest many other H. H. Scott components for moderate and high priced systems. **330 Stereophonic AM-FM Tuner**: "The cleanest and most transparent FM signals I have heard in a long time." — *High Fidelity*. "An AM tuner which is easily the best we have heard." — *Audiolab Test Report*. **130 Stereophonic Preamplifier**: ". . . SO much flexibility that it defies adequate editorial treatment." — *Hi Fi Review*. "We are convinced that this is one of the best stereo preamplifiers we have checked." — *Electronics World*.

**Accessory Case
Information**

There are several handsome accessory case styles available for H. H. Scott components. Most attractive are the beautifully crafted wood slip-on cases in your choice of oiled walnut, hand-rubbed mahogany and blond finishes. There is also an economical leatherette-covered metal case.

Here's how the Stereo-daptor works

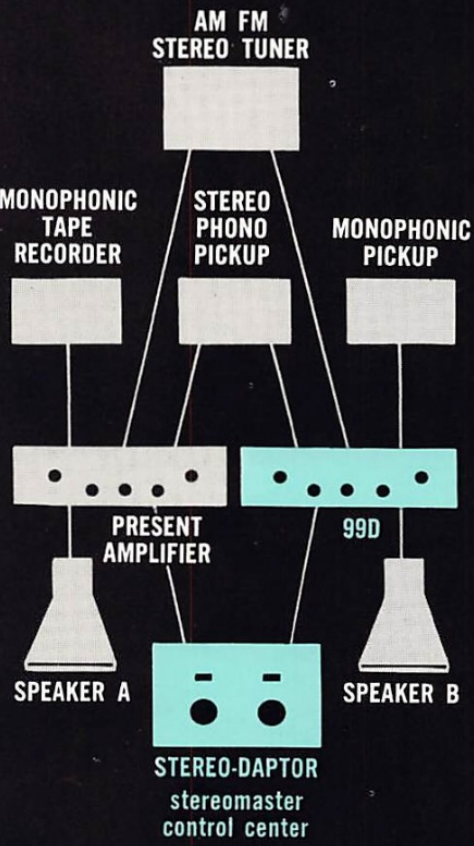

99D

22 Watt Complete Amplifier

This amplifier is ideal for those who want a top-quality monophonic system now, and wish to expand to stereo sound later. Together with the 135 Stereo-Daptor it also makes an excellent add-on system to existing amplifiers. Outstanding features include two low-level preamp inputs that enable you to use both a phono cartridge and tape head; extensive tape recording and monitoring facilities; and front panel stereo expansion switch. See page 18 for complete specifications.



135

Stereo-Dapter Stereomaster Control Center

The Stereo-Daptor permits control of two separate amplifiers from a central point. A Master Volume Control adjusts the volume levels of both channels simultaneously. Special switching lets you play stereo, reverse stereo, use your stereo pickup on monophonic records. No internal changes are required when used with H.H.Scott amplifiers.

1000

Counter-weight pre-adjusted at factory to give proper stylus pressure.

Controlled lateral damping minimizes sensitivity of arm to external vibration.

Overall height of arm may be adjusted from 1 3/8" to 2 1/2" so that arm will work with any turntable.

Precision ball bearings reduce friction as arm moves laterally across record.

Arm constructed of chrome anodized aluminum to reduce weight and minimize record wear.

Precision ground needle bearing reduces vertical friction to an absolute minimum.

Convenient handle gives positive control of arm when placing on record.

Lowest moving tip mass of any stereo cartridge. Reduces record wear and results in extended high frequency response.

Integrated arm and cartridge design assures proper alignment of stylus on record so that cross-talk is kept to unmeasurable levels.

Balanced-Coil construction and controlled air gap assures hum levels lower than with conventional designs.

Simple contact arrangement makes possible instant removal of cartridge for ease in cleaning.

.5 mil stylus assures minimum distortion, minimum record wear.

technical specifications

Tip Mass: Less than 1 mg. This tip mass is at least 50% lower than cartridges of conventional design.

Frequency Response: 20 CPS to 20,000 CPS.

High Vertical Compliance: Minimizes record wear and prevents damage even if cartridge is dropped on record.

Tracking Pressure: 3.5 grams for optimum response and minimum wear.

Output: 7 millivolts.

Cross-Talk: Better than -20 db.

London-Scott Matched Arm and Cartridge



Bottom view of cartridge showing positive contact arrangement and precision stylus construction.

710A



Stroboscopic Turntable

Description: The 710A is an integrated turntable system with built-in provisions for pickup arm mounting and scientific vibration isolation.

Acoustic Filtering: Torsional and mechanical filtering completely isolate the turntable from all extraneous acoustic, motor and room vibrations.

Rumble: 60 db below recording level.

Wow and Flutter: Less than 0.1% of rated speed.

Speed Controls: Push button selection of 33 1/3, 45 or 78 rpm speeds.

Dimensions: (Including pickup arm mounting board): 16 7/8" x 14 1/2"; depth from top of spindle to bottom of mechanism 7 1/8".

Power: 105-125 volts, 60 cycles AC.

Accessory Base: Hand-rubbed mahogany base available from your dealer.

Technical Specifications Amplifiers

399
Stereo
Tuner/Amp
(Amplifier
Section)

299
40 Watt
Stereo
Amp.

222
24 Watt
Stereo
Amp.

130
Stereo
Preamp

99D
22 Watt
Mono
Amp.

250
40 Watt
Power
Amp.

Power Rating	20/20	20/20	12/12	n.a. ³	22	40
% Harmonic Distortion	0.8	0.8	0.8	0.15	0.8	0.5
Frequency Response	20-30,000	20-30,000	20-30,000	19-35,000	20-30,000	12-60,000
% IM Distortion	0.3	0.3	0.3	n.a.	0.3	0.1
Hum Level	-80 db	-80 db	-80 db ¹	-80 db	-80 db	-85 db
Stereo Inputs	5	5	4	5	n.a.	n.a. ²
Speaker Outputs per Channel	4, 8, 16 ohms	4, 8, 16 ohms	4, 8, 16 ohms	n.a.	4, 8, 16 ohms	4, 8, 16 ohms
Scratch Filter	yes	yes	yes	yes	yes	n.a.
Rumble Filter	yes	yes	no	yes	yes	n.a.
Separate Bass, Treble	yes	yes	yes	yes	n.a.	n.a.
Tape Monitor	yes	no	no	yes	yes	n.a.
3rd Channel	yes	yes	yes	yes	n.a.	n.a.
Sensitivity on Phono	3 mv	3 mv	3 mv	3 mv	3 mv	n.a.
Sensitivity on Tape Head Input	3 mv	3 mv	3 mv	1.5 mv	3 mv	n.a.
DC Preamp Tubes	yes	yes	yes	yes	yes	n.a.
Equalization Curves	2	3	2	4	6	n.a.
Electronic Crossover	yes	yes	yes	yes	n.a.	n.a.
Balancing Provisions	yes	yes	yes	yes	n.a.	n.a.
Reverse Stereo	yes	yes	yes	yes	n.a.	n.a.
Mono Records with Stereo Pickup	yes	yes	yes	yes	n.a.	n.a.
Subsonic Cutoff	yes	yes	yes	yes	yes	n.a.
Loudness-Volume Control	yes	yes	yes	yes	yes	n.a.
Signal Lights	3	3	1	4	1	1
Dual Magnetic Inputs	yes	yes	no	yes	yes	n.a.
Dimensions in Accessory Case	16¼w, 7h, 14¼d	15½w, 5¼h, 13¼d	15½w, 5¼h, 13¼d	15½w, 5¼h, 13¼d	15½w, 5¼h, 13¼d	13w, 9½d, 7h

Technical Specifications Tuners

	399 Stereo Tuner/Amp (Tuner Section)	330 D Stereo AM-FM Tuner	310 C FM Tuner	311 D FM Tuner	320 AM-FM Tuner
Sensitivity for 20 db Quieting μ V	2	2	1.5	2	2.5
IHF M Sensitivity μ V	2.5	2.5	2	2.5	3
FM Detector Bandwidth	2 mc	2 mc	2 mc	2 mc	2 mc
FM IF Stages	2	2	3	2	2
FM Limiting Stages	2	2	3	2	2
Silver Plated Front End	yes	yes	yes	yes	yes
FM Cascode RF Stage	yes	yes	yes	yes	yes
Multiplex Output Jack	yes	yes	yes	yes	yes
Tuning Indicator	eyes	meter	meter	meter	eye
Stereo Phase Reverse Position	yes	yes	n.a.	n.a.	n.a. ³
Tuning Mechanism	plane- tary	plane- tary	plane- tary	plane- tary	slide- rule
% Harmonic Distortion on FM	0.8	0.8	0.5	0.8	0.8
Capture Ratio (db)	6	6	2.2	6	8
10 kc Whistle Filter	yes	yes	n.a.	n.a.	yes
AM Bandwidth Positions	2	3	n.a.	n.a.	2
Wide Range AM Detector	yes	yes	n.a.	n.a.	yes
AM Loopstick Antenna	yes	yes	n.a.	n.a.	yes
Tape Recorder Outputs	yes	yes	yes	yes	yes
Output Level Controls	yes	yes	yes	yes	yes
Separate AM & FM Sections	yes	yes	n.a.	n.a.	no
Automatic Gain Control	yes	yes	yes	yes	yes
Output Voltage for 100% Modulation	n.a. ³	4-6	4-6	4-6	4-6
Interstation Noise Suppressor	no	no	yes	no	no
Total Hum and Noise (db below 1 volt)	66	66	66	66	66
Dimensions in Accessory Case	16 $\frac{3}{4}$ w, 7h, 14 $\frac{1}{4}$ d	15 $\frac{1}{2}$ w, 5 $\frac{1}{4}$ h, 13 $\frac{1}{4}$ d	13 $\frac{1}{2}$ w, 5 $\frac{1}{4}$ h, 10 $\frac{1}{4}$ d	13 $\frac{1}{2}$ w, 5 $\frac{1}{4}$ h, 10 $\frac{1}{4}$ d	15 $\frac{1}{2}$ w, 5 $\frac{1}{4}$ h, 13 $\frac{1}{4}$ d

NOTES: 1. Below max. output on high level inputs. Noise equivalent to 3 mv on mag. inputs

2. Single channel input for signals of .5 or 1.5 volts.

3. n.a. — not applicable.



H. H. Scott stereo hi fi components offer you a big advantage when you are planning your music system. They can be placed anywhere in your room . . . on a bookcase, in a buffet, even built into a wall. H. H. Scott components are compact, flexible, beautifully designed. Find out how leading interior designers plan hi fi components into the homes they decorate. Write for a FREE copy of H. H. Scott's new booklet "How To Use Hi Fi Components In Your Decorating Plans."



H. H. SCOTT

111 Powdermill Road, Maynard, Mass.

Export:

Telesco International Corporation
36 West 40th Street, New York City, N. Y.